

Vacuum Pump



Model 4565 Series

25 inHg max. vacuum
47.5 CFM open flow
15 psi max. pressure

Product Features

- Lubricated operation
- Pulley driven (multiple speeds available)
- Rugged construction/low maintenance
- Essentially pulse-free service

Includes

- Oil reservoir AA960A-1
- 6.5" P.D. pulley AC376B for "A" section belts
- Filter/muffler AD560 (2) on vacuum pump
- Filter AD750 (Compressor)
- Fan AD721
- Vacuum-actuated lubricator V40C (2)
- Pressure lubricator AD730

Recommended Accessories

- Base AB322C
- Vacuum relief valve AA308
- Pressure relief valve AA307
- Vacuum gauge AA640
- Pressure gauge AA644B
- Oil AD220
- Belt guard AB331B-1
- Repair kit K242 (Vacuum Pump)
- Repair kit K243 (Compressor)

Compressor



Product Dimensions (inches, mm)

Dimensions are for reference only

Vacuum Pump

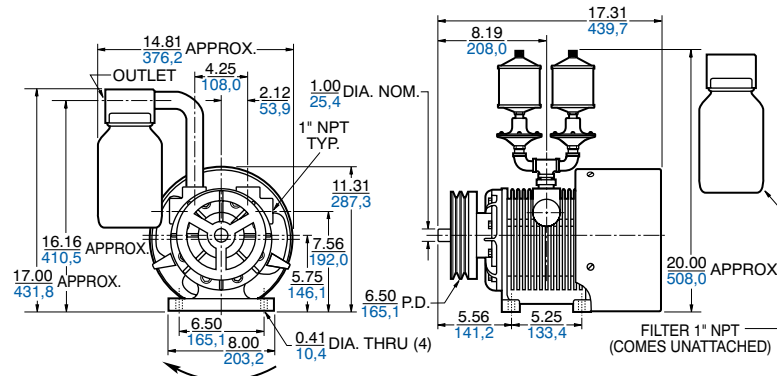

Compressor

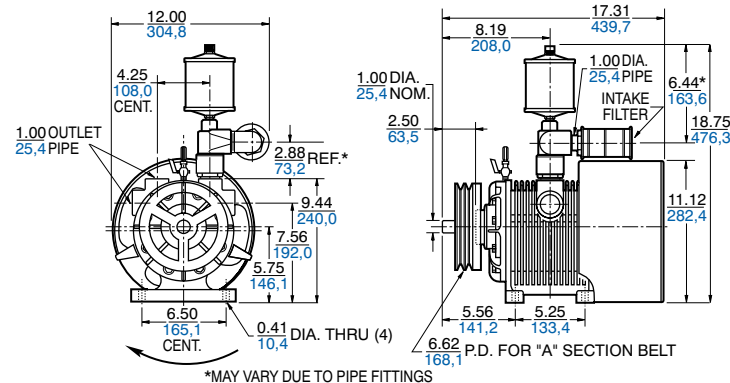

Product Specifications Note: "P" models are pressure, "V" models are vacuum.

Model Number	Motor	Base	Belt Guard	RPM	HP	kW	Net Weight	
							lbs	kg
4565-P3	—	—	—	1725	5	3,7	103	46,4
4565-V6*/4565-V6A	—	—	—	1725	3	2,2	105	47,3
4565-V15D	—	•	•	1350	3	2,2	127	57,2
4565-V15D-T338	230/460-60-3	•	•	1350	3	2,2	187	84,2
4565-V15E	—	•	•	1725	3	2,2	127	57,2
4565-V15E-T338	230/460-60-3	•	•	1725	3	2,2	187	84,2

*Model 4565-V6 is the stock version and comes with plumbing unattached.

Product Performance

